

CAP APPLICATOR A2000

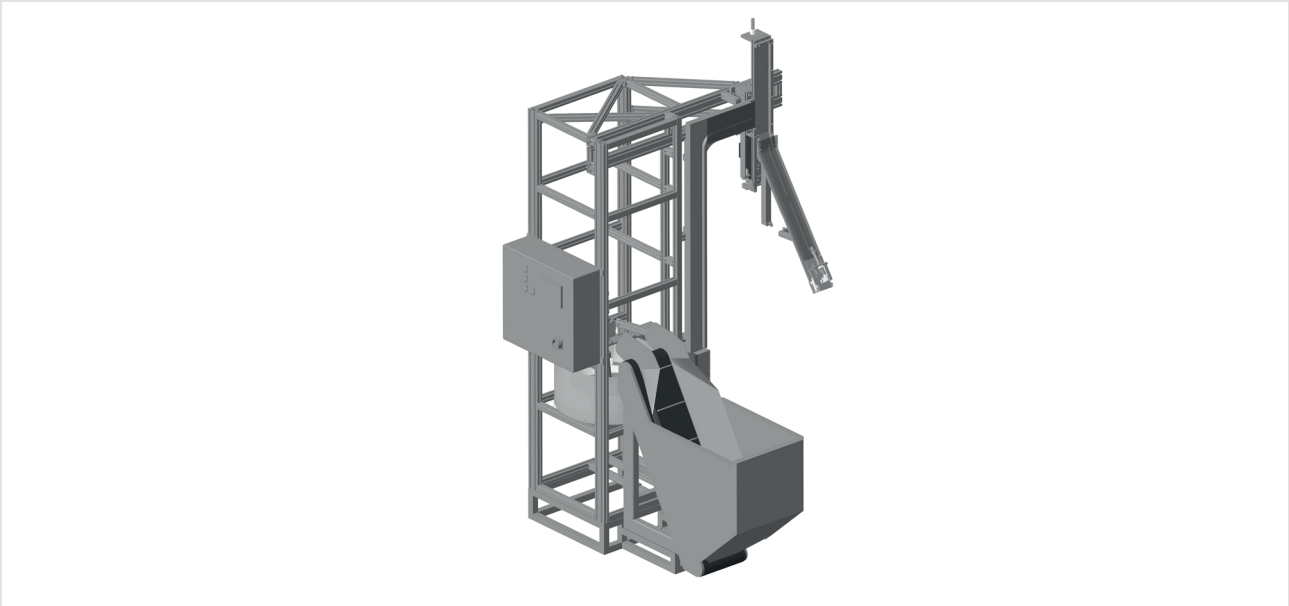

BRIEF DESCRIPTION

Using our A2000 cap applicator, SIGL shrink or snap caps can be conveniently and securely placed on almost all industry-standard fitting systems, in this way ensuring tamper-proof closures for your beer. Caps are conveyed from the storage bunker to the sorting drum. A built-in control feeds caps to the correct position on the feed rail using electronic number monitoring. As barrels pass by, caps (SIGL shrink or snap caps) are automatically removed from the rail. In so doing, the movable feed rail automatically compensates for any height differences of the drums. The cap applicator is designed for mixed operation and adapts to the respective barrel or keg height.

TECHNICAL INFORMATION

KEG PROCESSING & PERFORMANCE

- Cap type: Snap caps, fitting type: Basket fitting
- Capacity: max. 2,000 kegs/hour (depending on barrel or keg and fitting combination)
- Kegs: Manufacturing tolerances are covered
- Kegs: 30l DIN, 50l DIN, 20l DIN
- Keg conveyor belt speed: max. 12 m/min
- Centric feeding of barrels and kegs is ensured by the operator through barrel stopping
- Electric / pneumatic keg height adjustment, using a selector switch
- Pneumatic cylinders / valves: from the company FESTO
- Barrel and keg height monitoring via a light barrier: from the company SICK

STORAGE BUNKER & SORTING DRUM

- Storage bunker made of VA sheet metal for keg protector caps
- max. capacity: 1,000 caps (depending on cap type)
- Storage bunker with integrated steel conveyor
- Sorting drum with electrical-optical position detector for the caps
- Sorting drum drive: from the company SEW - 0.18 kW
- Pneumatic conveyor shaft to the applicator rail
- Fan blower: from the company LEISTER - 0.25 kW / delivery height - 1,500 mm
- Applicator rail with controlled rail extension and rocker for mounting caps on the keg flange
- Control using 2 light barriers: from the company SICK, 24 Volts

CONTROL & CONNECTION

- Control via PLC: from the company SIEMENS S7-1500
- Display of unit operating status via an indicator light / acoustic signal
- Control cabinet: Manufacturer RITTAL, V2A housing, electric connection load - 1.20 kW, voltage 400 Volts - power consumption/duty 40-50 %
- Air consumption: approx. 180 l/min (depending on load)

SECURITY

- Structure according to Performance Level C (extension to PL D is possible)
- Safety grille beneath the applicator to prevent interference, (obstruction or intervention)
- Safety grille at keg inlet (adapted to the largest possible barrel or keg size)
- Confirmation switch on the access doors

HOUSING & DIMENSIONS

- Housing & dimensions
- Framework components made of anodised aluminium profile
- Adjustable height calotte feet
- Substructure for belt height (minimum floor-belt height 615 mm) made of V2A rectangular tubing with adjustable calotte feet
- Adjustable position of keg conveyor (running to the left or to the right)