

SHRINK FIT MACHINE AS1000

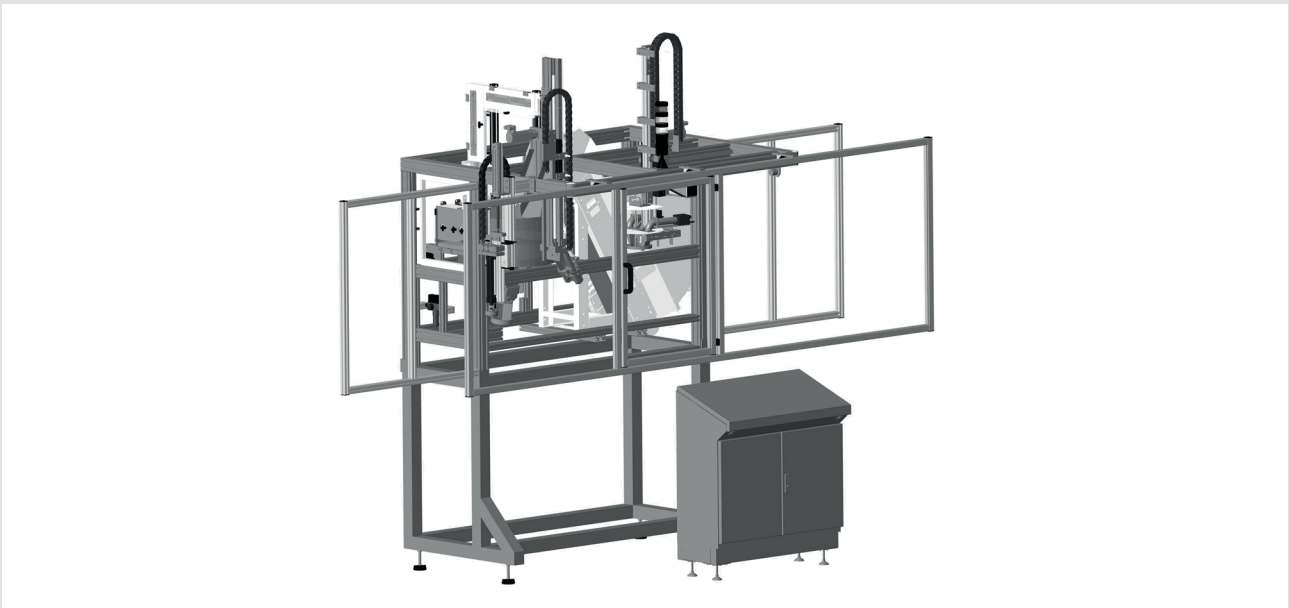

BRIEF DESCRIPTION

The compact AS1000 cap applicator and shrinker integrates functions of applying and shrinking SIGL shrink caps in one machine and fits into very confined spaces. In this way, caps are first conveyed from the storage bunker to the sorting drum. A vibrator feeds the caps to the correct position on the feed rail with electronic number monitoring. As barrels pass through, caps are automatically removed from the rail and placed onto the fitting. Barrels are then moved to the shrink station and centred there. The shrink head with automatic height detection shrinks the SIGL shrink cap around the fitting in a time regulated and temperature-controlled manner, thus ensuring original tamper-proof closure of the barrel. The AS1000 cap applicator and shrinker is designed for mixed operation and adapts to the respective barrel or keg size.

TECHNICAL INFORMATION

KEG PROCESSING & PERFORMANCE

- Cap type: Shrink caps
- Fitting type: M-Type, A-Type, G-Type, D-Type, S-Type
- max. capacity: 1,000 kegs/hour
- Kegs: Manufacturing tolerances are covered, slim kegs possible
- Keg conveyor belt speed: max. 12 m/min
- Centric feeding of barrels and kegs is ensured by the operator
- Automatic keg height adjustment and fine adjustment of the cap positioning head through use of servo motors, manufactured by SEW and rack and pinion drive
- Keg stop via pneumatic cylinder, for centring the positioning unit in the shrink unit
- Electric air heater for double shrink nozzle
- Air heater: Manufacturer LEISTER - 2 x 3.0 kW - power consumption/duty 60-70%

STORAGE BUNKER & SORTING DRUM

- made of VA sheet metal for KEG protective caps
- max. capacity: 1,000 caps (depending on cap type)
- Storage hopper with integrated vibrating feeder
- Sorting drum with electric-optical positional detection of the caps, and fan blower device into the conveyor shaft
- Sorting drum drive: Manufacturer SEW - 0.18 kW
- Pneumatic conveyor shaft onto the applicator rail

CONTROL & CONNECTION

- Control via SPS: Manufacturer SIEMENS S7-1500
- Display of operating status of system via an indicator light / acoustic signal
- Control cabinet: Manufacturer RITTAL, V2A housing, electric connection load - 8.0 kW, voltage 400 Volts - power consumption / duty 40-50 %
- Air consumption: approx. 300 l/min (depending on load)

SAFETY

- Construction according to Performance Level C (extension to PL D possible)
- Safety grille beneath the feeder to prevent tampering, obstruction or intervention
- Safety grille at the keg feed-in (adapted to the largest possible keg size)
- Confirmation switch on the access doors

HOUSING & DIMENSIONS

- Framework parts made of anodised aluminium profile
- Adjustable height calotte feet
- Substructure for conveyor height (minimum floor-belt height 615 mm) made of V2A square tubing with adjustable round feet
- Adjustable position of keg conveyor (running to the left or to the right)